

- 1
- 2
- 3
- 4
- 5
- 6
- 7
- 8
- 9
- 10
- 11
- 12
- 13
- 14
- 15
- 16
- 17
- 18
- 19

MAIN SPECIFICATIONS

Version **B**: mounting on both sides
 Stainless steel precision casting AISI CF-8 **NI**
 Matte shot-blasted finish **GS**

FEATURES AND APPLICATIONS

Mounting blocks GN 3492 quickly and easily fasten standard parts with external thread, such as spring plungers or setting bolts, perpendicular to the mounting plane. The slotted holes and the locating thread allow for positioning of the mounting blocks in two directions.
 To prevent unintentional adjustment, the standard part can be secured with a clamping thread lock, a lock nut or a grub screw.

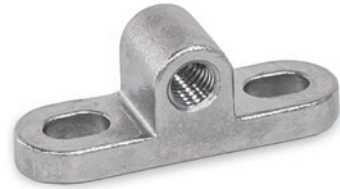

Application example

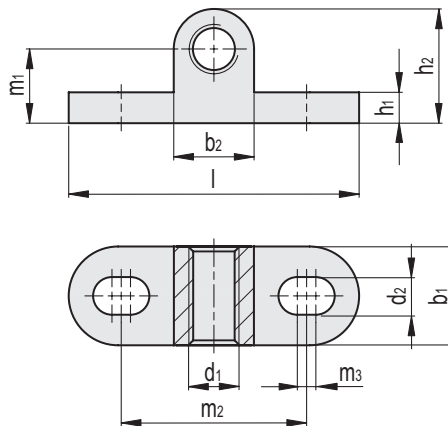
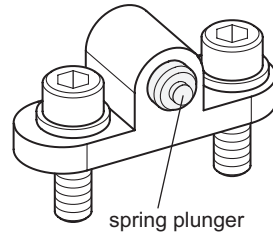

Code	Description	d1	d2 For screws	b1	b2	h1	h2	Length l	m1	m2	m3	⚖
GN.31081	GN 3492-8-M4-B-NI-GS	M 4	M 3	8	7	2.5	9.5	25	6	16	1.5	5
GN.31083	GN 3492-10-M5-B-NI-GS	M 5	M 4	10	8	3.5	12	32	8	20	2	9
GN.31085	GN 3492-12-M6-B-NI-GS	M 6	M 5	12	10	4	15	38	10	24	2.5	15
GN.31087	GN 3492-16-M8-B-NI-GS	M 8	M 6	16	13	5	18.5	47	12	30	3	35
GN.31089	GN 3492-20-M10-B-NI-GS	M 10	M 8	20	16	6	23	60	15	38	4	58

Indexing and positioning elements